

# LOADER/BACKHOE SAFETY TRAINING



# STUDENT MANUAL

1

# Introduction

The loader/backhoe is a versatile machine capable of performing many tasks around the worksite. It's ideal for most trenching work that is done on a construction site. The loader is perfect for moving and loading soil as well as heavy objects into a truck. It can be used for light demolition and with special attachments in can increase its capabilities in this area. The backhoe is often used for crane type work.

This Student Manual is intended to cover the basic topic concern the operation and use of the loader/backhoe. This manual is NOT intended to replace the manufacturer's manuals provided with the machine. Those who are involved with the use of the loader/backhoe need to read and understand these documents.

**SAMPLE**

# Basic Components

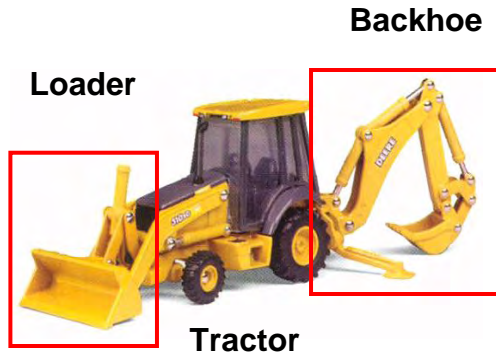

The basic component of the loader/backhoe is the tractor. Most tractors used in loader/backhoes are now designed to be used in conjunction with the loader attachment and the backhoe attachment.

The loader is attached to the front of the tractor and its arms are raised and lowered by hydraulic cylinders. A bucket is attached to the lifting arms and has a hydraulic cylinder for tipping the bucket forward and backward. The capacity of the bucket varies dependent on the size of the tractor. Buckets can be fitted with teeth to increase the machine's digging ability.

The backhoe is attached to the rear of the tractor by a hinge arrangement which allows the boom and bucket assembly to swing to the right or left. Swinging this assembly is accomplished through the use of two hydraulic cylinders which function in a push-pull manner. Also, boom, stick and bucket functions use hydraulic cylinders.

Stabilizers are attached to each side of the backhoe to provide stability when the boom is swung from one side to the other.



## Pre-Operations Checklist

- Check engine, coolant, & hydraulic fluid levels
- Check for broken and/or dirty glass
- Check all functions for smooth operations
- Check transmission for smooth operation
- Check brakes
- Inspect hydraulic hoses
- Check that all safety devices & guards in place & functional
- Inspect bolts, welds, & pins for proper condition
- Inspect Rollover Protective Structure
- Inspect seat belt
- Check tires for condition, inflation, & missing valve caps
- Inspect all lights, gauges, horn & alarms
- Inspect engine compartment for leaks & trash build-up

***Refer to the machine's Operation & Maintenance Manual for a complete list of inspection items.***

The above inspection checklist is a general list of items that need to be inspected prior to the machine being placed into operation.

When a machine is used by several operators in the course of a shift, each operator should perform a pre-operation inspection before operating the machine during that shift. Even though this will seem redundant, the operator needs to insure the machine is safe to operate.

# Inspecting the Tractor



Check the following:

- Engine oil & coolant
- Hydraulic fluid levels
- Glass for dirt & damage
- Transmission for smooth operation
- Brakes
- Safety devices
- Seat belt
- Tires for condition & inflation
- Lights, gauges, horn & alarms
- Cab cleanliness
- All controls for proper labels

Minor injuries to the operator are often a result of poor housekeeping. Dirty glass is common during excavating and can seriously affect visibility. Keeping window cleaning supplies on the machine can greatly decrease this problem.

## Inspecting the Backhoe



Check for the following:

- Damaged stabilizer arms & pads
- Bent or damaged hydraulic cylinders
- Worn hinge pins & bushings
- Damaged & leaking hydraulic lines
- Smooth operation through all functions
- Damaged or loose teeth on bucket
- Worn stick extension slide pads
- All welds for cracks

The operator should check to see that the machine is being properly lubricated. The operator's manual will provide a complete lubrication chart.



# Inspecting the Loader



Check for the following:

- Damaged lift arms
- Bent or damaged hydraulic cylinders
- Worn hinge pins & bushings
- Damage & leaking hydraulic lines
- Smooth operation through all functions
- Damaged or loose teeth on bucket
- Bent or damaged bucket links
- All welds for cracks

The loader assembly attaches to the front of the tractor by two lift arms and hydraulic cylinders. The arm hinges need to be inspected for wear and proper lubrication. Each arm has a hydraulic lift cylinder used to raise and lower the bucket. Inspect the cylinders for fluid leaks and damage to the cylinder rods.

## Operator's Manual

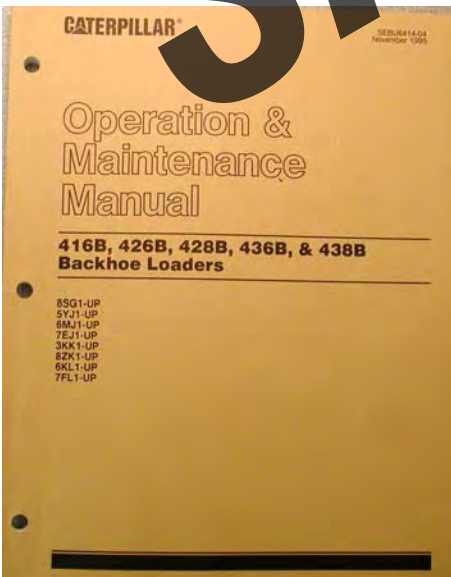

The operator's manual is required to be on the machine at all times, intact and readable.

It is best to take time to review the contents of the manual with students at this time.

Each operator is to have read and understood the manual before operating a machine.



# Typical Weight of Components

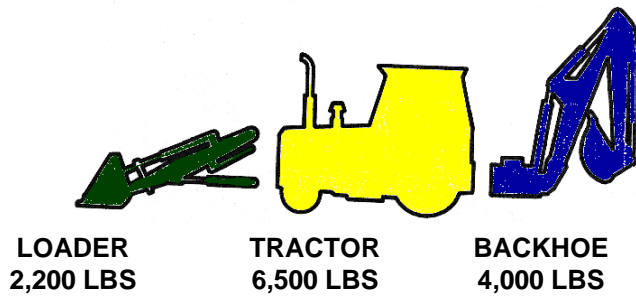

A typical loader/backhoe found on a job site can weigh from 12,000 to 16,000 pounds. Emphasize how heavy the machine is and because of its size how much potential it has for doing damage when not properly operated.

Because of their weight, great care is required when removing or installing a loader and/or a backhoe. Always follow the manufacturer's guidelines and use proper equipment for handling these components.

## Machine Stability

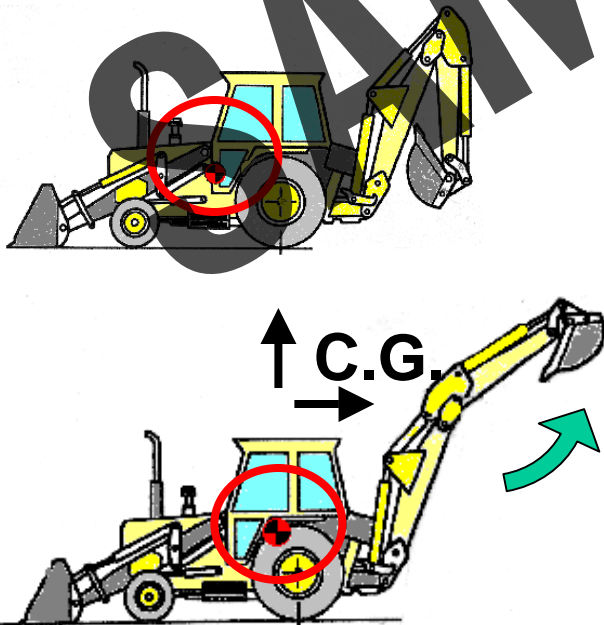

As a backhoe is raised and extended, the center of gravity of the machine rises vertically and moves toward the rear of the machine. This vertical change in the center of gravity affects the machine's lateral or side to side stability. Also, when a backhoe is extended and swung to the side, lateral stability decreases.

# Machine Stability

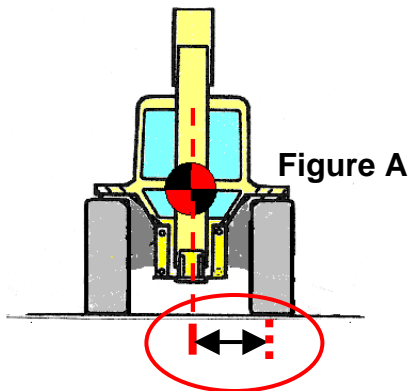

When the loader/backhoe is on level ground and the backhoe is located directly behind the machine, the machine's center of gravity of the machine is centered between the wheels as shown in the figure A. As the traversed slope increases, the machine's stability decreases because the horizontal distance of the center of gravity relative to the the wheels on the downhill side decreases as shown in figure B. If the slope is increased to where the center of gravity moves beyond wheel, the machine will tip-over.

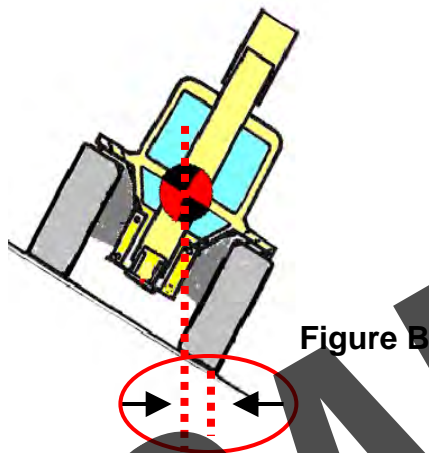

Traveling fast over sloping ground that is rough can cause the machine to bounce and rock from side to side thus increasing the probability of a rollover.

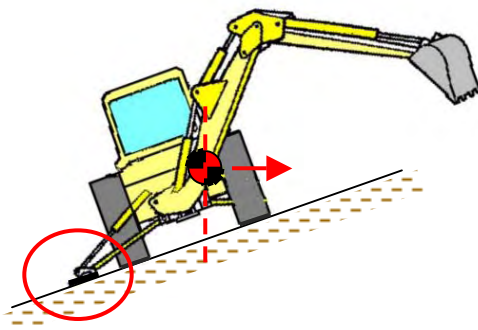

When traversing a steep slope, the operator should first attempt to locate an alternate route. If none exists, then the machine's stability can be increased by swinging the backhoe up slope. This will move the machine's center of gravity away from the downhill wheels, thus increasing stability. When performing this maneuver, the operator must be alert to avoid striking ground objects with the backhoe when traveling. Also, the boom should not be raised while on the slope. This could result in shortening the distance from the center of gravity relative to the downhill wheel, resulting in a rollover.

The downhill stabilizer can be lowered to help stabilize the machine should a rollover begin, but again this needs to be done with great care. The lowered stabilizer could strike an unseen object, causing the operator to loose control of the machine.

Always traverse a slope SLOWLY!!



# Machine Stability

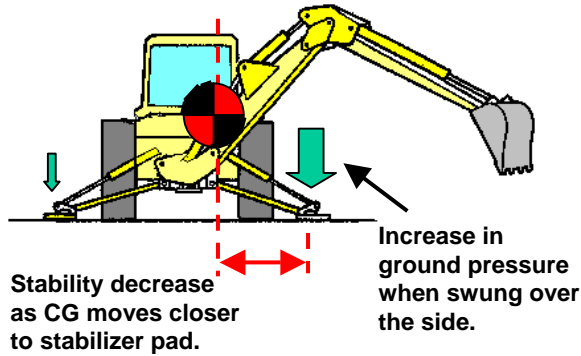

When a boom is swung to the side, the center of gravity of the whole machine shifts toward the side also. If the bucket is full of material or if a load is suspended from it, the center of gravity shifts even more to the side. If the combined center of gravity of the machine and load moves beyond the stabilizer, the machine will tip over.

As the bucket is swung to the side, the pressure the stabilizer pad imposes on the ground increases. If that pressure exceeds the soil bearing strength for the ground, the stabilizer will sink, thus increasing a potential for a tip-over.

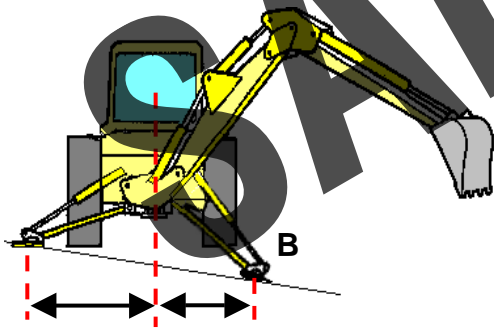

When leveling the machine on sloping ground, the stabilizer on the downhill side of the loader/backhoe has to rotate farther down to raise that side of the machine. Thus, the horizontal distance from the machine's center of gravity to the downhill stabilizer decreases. Shortening this distance decreases the machine's stability which in turn decreases the amount of weight the machine can safely lift. This condition is at its worst when the bucket is fully swung to the side.

# Machine Stability

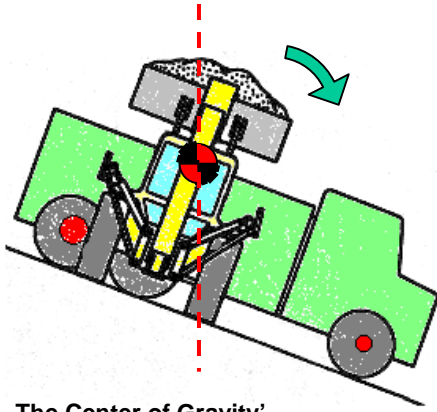

The Center of Gravity can move beyond the wheels as the loader bucket is raised.

When a loader bucket is full and raised up, the total center of gravity of the machine rises vertically also. When the machine is on a slope and the load is raised as shown in the above figure, the center of gravity moves toward the downhill side of the machine and if it moves past the downhill tires, the machine will tip over.

Loading trucks on a slope as shown above should be avoided. The truck needs to be repositioned so that the machine is relatively level.

**Never load on a side slope**



It is often necessary to operate a loader/backhoe in soils that have been previously excavated. This condition can affect the machine's stability, especially when working on a slope. As the machine's rear drive wheels attempt to gain traction, they can dig into soft soil and cause the rear of the machine to swing downhill. As this occurs, the machine's stability decreases, which increases the likelihood of a tip-over. Also, as the operator attempts to prevent the rear of the machine from swinging downhill, the maneuvering of the machine can result in a tip-over.

Before traversing soft, sloping ground, assess conditions to determine how soft the soil is and the amount of incline. If any doubt exists about moving the machine across such terrain, look for another route. If there is none, the loader/backhoe can be used to level the route somewhat to decrease chances of lost stability.

# Machine Stability

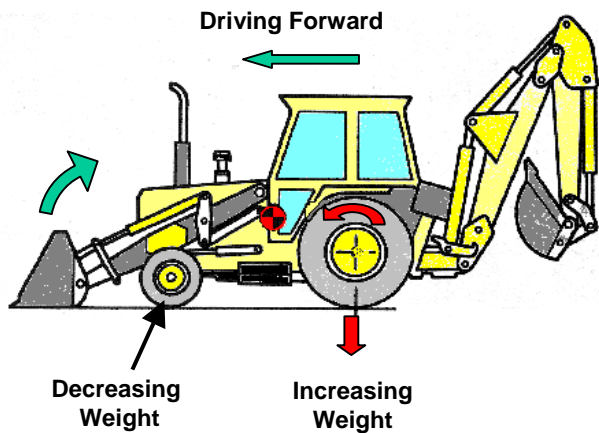

The machine attempts to rotate clockwise as it accelerates.

When **Driving Forward**, the forward driving torque transfers weight from the front wheels to the rear wheels.

When a loader/backhoe is put into motion, various dynamic forces come into play. When forward power is applied to the rear drive wheels, the machine attempts to rotate in the opposite direction, or backwards. How much the machine attempts to rotate backwards depends on how fast it is accelerated. When the machine is accelerated forward slowly, the amount of backward rotation is small, and when the machine is rapidly accelerated forward, a greater amount of backward rotation occurs.

As a result of this backward rotation, a portion of the weight on the front wheels is transferred to the rear wheels. The amount of weight transfer depends on how rapidly the machine is accelerated. When the machine reaches a constant travel speed, the backward rotation diminishes and the load which was transferred to the rear wheels returns to the front wheels. During the period that the weight on the front wheels is being transferred to the rear ones, the steering capacity of the machine decreases. With less weight on the front wheels, traction is reduced and therefore the front wheels lose ability to steer the machine.

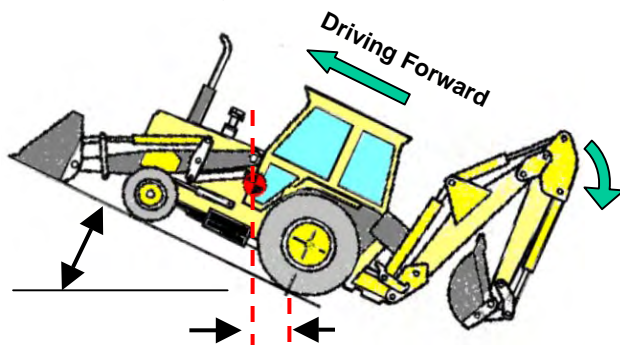

Center of Gravity moves closer to the rear wheels as the machine's angle of climb increases.

When a loader/backhoe moves up an inclined slope, the horizontal distance between the machine's center of gravity and the rear wheels decreases. This change results in the machine becoming less stable in the rearward direction. The previous slide showed how the stability of the machine is affected when it is accelerated in the forward direction. When these two effects are combined, the machine's rearward stability is greatly reduced.

To maximize the stability of a machine in this situation, keep the backhoe retracted up to the rear of the machine and accelerate as slowly as possible.



# Machine Stability

When Driving Backwards the reverse driving torque will transfer the weight from the rear wheels to the front wheels.

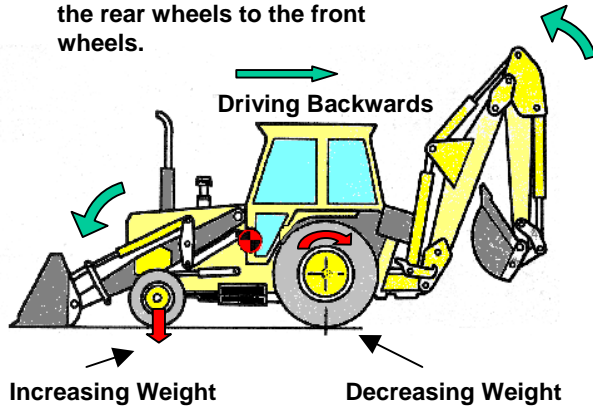

Previous page showed how accelerating forward transfers weight from front wheels to rear wheels. When accelerating backwards, the opposite occurs. As the machine is accelerated in reverse, it rotates toward the front. The amount of load transfer that occurs is depends on how fast the machine accelerates. The load transfer when backing up is not nearly as noticeable as when the machine is moving forward.

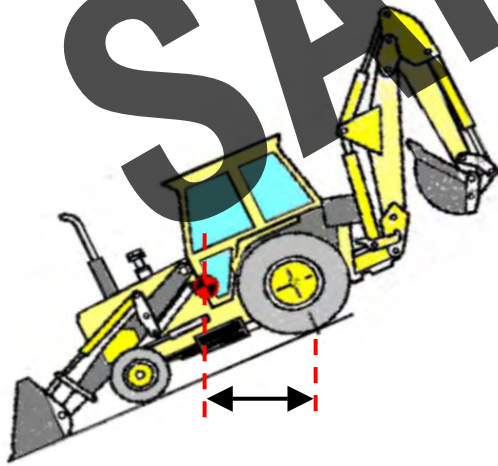

Center of Gravity moves further from the rear wheel as the machine's angle of decline increases. This change results in loss of traction on the rear wheels allowing the machine to slide.

The accompanying diagram shows how as the angle of incline increases, the horizontal distance from the rear wheel's contact with the ground and the machine's center of gravity increases. Depending on the amount of incline, a portion of the weight carried by the rear wheels will be transferred to the front wheels. This decreased weight on the rear wheels results in a loss of traction and control due to sliding.

# Machine Stability

When the loader bucket is used to raise the front wheels off of the ground, traction on the rear wheels increase.

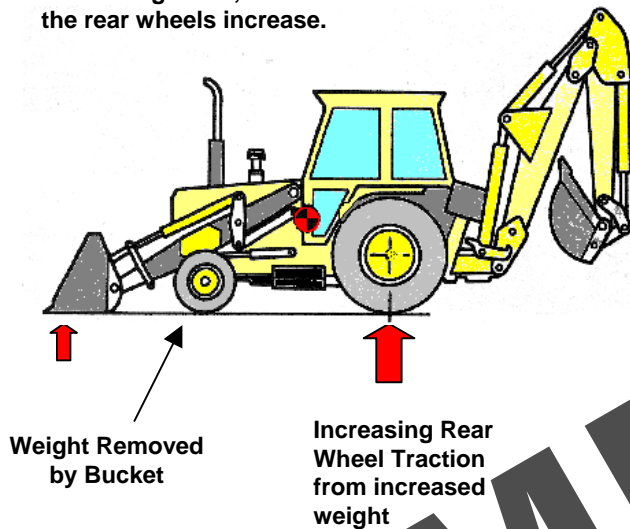

On occasion it may be desirable when backing up to increase traction on the rear wheels. By lowering the loader bucket to the ground and raising the front wheels slightly, a certain amount of weight can be transferred to the rear wheels. When doing this maneuver, the bucket should be tilted slightly forward to prevent the rear of the bucket from digging into the ground.

SAMPLE

# Operator Awareness Factors

Several factors can affect the operators ability to stay focused on operating the machine.

## FATIGUE & HUNGER

**Fatigue & Hunger:** Fatigue can result from working too many hours, lack of sleep, hunger or monotonous, repetitive work. When an operator shows signs of fatigue, he should be relieved to get rest or exercise to refresh his alertness.

## WEATHER: HEAT, COLD

**Weather:** Many loader/backhoes are open to the elements. An operator needs to dress appropriately for the weather to prevent stress on his body.

## EMOTIONAL LEVEL

**Emotional Level:** Operators under emotional stress may not be able to stay focused. It may be necessary at times to remove such an operator from a machine until emotional equilibrium is restored.

## PHYSICAL HEALTH

**Physical Health:** Operators suffering from health problems affecting their machine operating ability should not be allowed on a machine. Even workers taking cold medicine may have their alertness compromised.

## WORKING CONDITIONS

**Working Conditions:** Some worksites that have many activities occurring simultaneously can distract an operator. He must be able to block out such distractions while operating a machine.

## OTHER PEOPLE

**Other People:** People should not attempt to talk to or in any way distract an operator who is operating a machine. Wait until he is finished with an operation before approaching or talking to him.

SAMPLE

## For Safe Operation

- Never Take Anything For Granted
- Face the Machine When Climbing on and off
- Keep The Machine Clean
- Clean Mud And Grease From Shoes
- Avoid Loose Clothing And Jewelry
- Wear Protective Equipment
- Never Operate Machine Without Protective Guards
- Always Check Height, Width, and Weight Restrictions
- Keep all Safety Devices in Place and Working Order
- Plan Ahead
- Learn Beforehand About the Work Area

The above is a list of items which affect the safety of loader/backhoe operations. The merits of each item should be discussed and class members invited to add additional items to the list. If there are company policies regarding the operation of this machine, now is a good time to discuss those also.

### Seat Belts

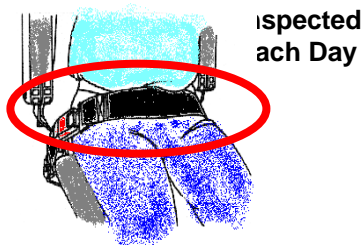
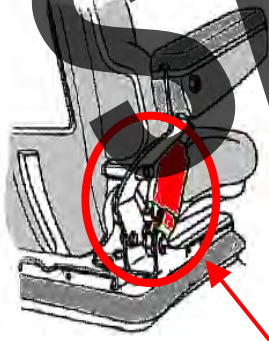

Inspected  
each Day

Loader/backhoes are equipped with seat belts and which should be worn at all times. On rough terrain, a seat belt will keep the operator in his seat allowing him to maintain control of the machine. In the event of a rollover, a seat belt will keep the operator within the confines of the rollover structure.

Before operating the machine each day, an operator is to inspect the seat belt for damage and proper operation.

- Must Be Worn When Operating The Machine

## Climbing On And Off The Machine



When mounting or dismounting a loader/backhoe, the operator should always face the machine and use the three point contact method. This method is simply keeping two hands and a foot or one hand and two feet in contact with the machine when climbing. By following this method many slips and falls can be prevented. Also, before climbing onto the machine, the operator should check his feet for mud or grease which could cause him to loose his footing.

The machine should always be mounted using the provided steps and hand holds. Never attempt to mount the machine by climbing over the rear of it. When dismounting the machine, never jump off. Serious leg, foot and ankle injuries can result from doing so.

### Job Site Safety

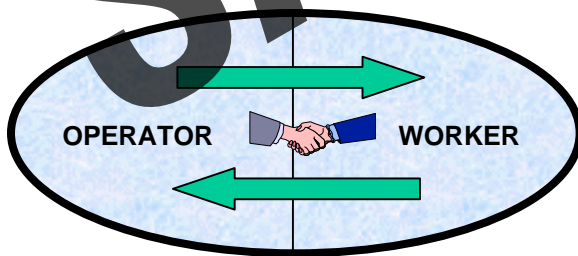

**EVERYONE IS RESPONSIBLE FOR HIMSELF AND THE OTHER PERSON**

Job site safety is every one's responsibility. When performing operations with a loader/backhoe, the operator of the machine and those assisting him on the ground need to work together as a team. Those on the ground need to notify the operator if they notice anything out of order with the machine. The operator needs to be aware of where workers on the ground are and stop operations when anyone comes within range of the machine. Everyone on the job site is responsible for himself and the other person.



## Danger Area

When the backhoe of a loader/backhoe is in operation, no one should enter the full swing area of the backhoe. The operator's vision of this area is not always clear and anyone entering may not be seen by the operator.

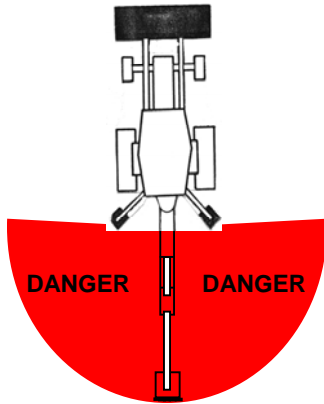

## Danger Area

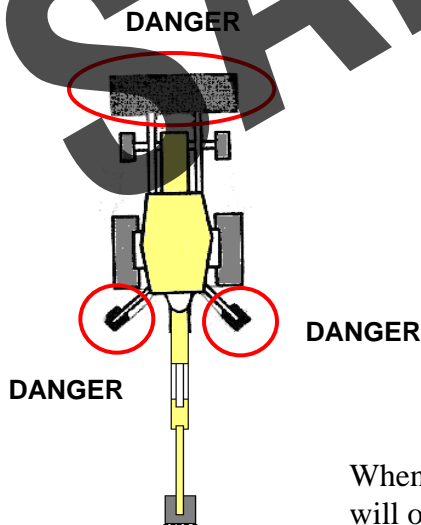

When a backhoe is being used for excavating, the machine will often move around the ground. Workers standing close to the stabilizers or the loader bucket could be injured when the machine bounces.

# Eye Contact

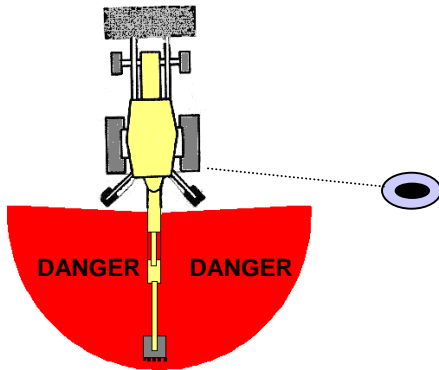

Establish eye contact with the operator before entering the danger area.



Before a worker enters the swing danger area, he must establish eye contact with the operator. The worker then must wait until the operator signals him that it is safe to enter this area. The operator should not move the backhoe until the worker has cleared the area. When it is necessary for the worker to remain in this area while the operator performs an operation, extreme care must be exercised and the worker needs to remain in the operator view.

Always Work Facing  
The Machine

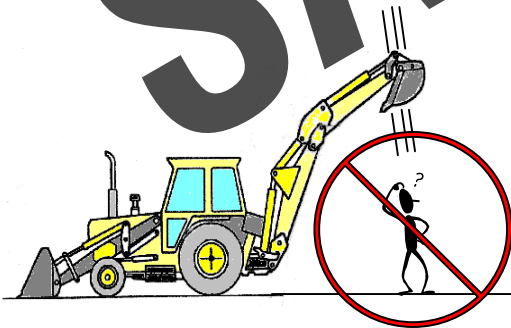

When working around a loader/backhoe, the worker should always work facing the machine. He should consider the machine as a continuous threat to his safety and thus constantly keep an eye on its movements.

# Excavating Hazards



**Before excavating, determine the location of all underground utilities and other buried hazards.**

Before any excavating work begins, the location and type of all buried hazards needs to be determined. Utility companies should be contacted for the location of their buried service lines, vaults or other objects. In some areas it may be necessary to contact various agencies to discover this information. It may be needful to obtain the service of a company that specializes in locating and identifying buried objects. When the excavation approaches a buried object, hand excavating should be done to avoid accidentally striking the object with the backhoe.

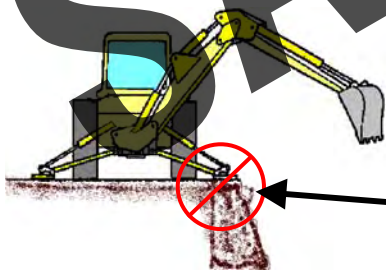

## Excavating Hazards

**Avoid setting stabilizer close to the edge of the trench.**

The stabilizers of a backhoe need to be set far enough from the edge of a trench to avoid a cave-in. Avoid placing the stabilizers closer than two feet from the edge. Depending on soil structure, this may not be sufficient. Remember, when the backhoe is swung to the side, the ground pressure from the stabilizer pad increases. The amount of pressure is depends on the weight being swung to the side. When setting up the backhoe near a trench, confer with the on site 'designated competent individual' responsible for establishing safety requirements for trenching to determine how close the machine can be to the trench edge. The rule of thumb for setup on unstable soils is: The distance the stabilizer is from the trench edge is equal to the depth of the trench.

19



# Excavation Hazards

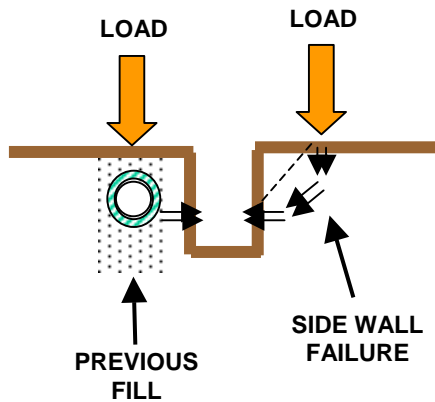

Placing the stabilizer pads or traveling too close to the trench walls can result in a trench collapse. The machine may fall into the excavation.



Trenches that are being excavated in previously filled areas are very susceptible to wall collapse. When traveling, keep the machine parallel to the trench and avoid traveling close to the edge.

## General Trench Precautions

- 
- Keep material & equipment a minimum of 2 ft from edge of excavation. Greater distances may be required based on soil stability.
  - Provide barricades or equivalent to prevent people from falling into trench.
- The diagram shows a cross-section of a trench. A vertical line is drawn from the top edge of the trench down to the bottom. A horizontal line is drawn from the top edge of the trench to the vertical line. A double-headed arrow between these two lines is labeled '2 ft min.'.



Material excavated from a trench should be placed a minimum of two feet from the edge of the trench. This distance may need to be greater depending on soil type. The slope of the spoil pile should be flat enough to prevent material from sliding into the trench.

Also note in the above picture that there are workers in the trench without adequate shielding or shoring in place.

# Lifting Loads

When lifting a load with the backhoe, refer to the operator's manual for specific load ratings at different radii and boom positions.

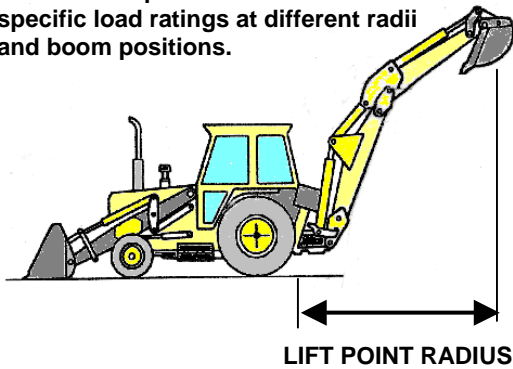

The operator's manual for each machine will include a section on lifting with the backhoe. This section includes information on lifting capacity for various radii of operation and where and how the loads are attached to the backhoe.

The term 'radius' refers to the horizontal distance from the swing hinge pin to the point on the bucket where loads are attached.

## Load Capacity Chart

EXAMPLE CHART

Lift Point Radius	Rated Capacity
<b>Backhoe Straight Back, Standard Stick</b>	
5.9 ft	8624 lbs
9.8 ft	5170 lbs
12.5 ft	4103 lbs
14.1 ft	3520 lbs
15.4 ft	<b>3058 lbs</b>
<b>Backhoe Swung to Side, Standard Stick</b>	
5.9 ft	7370 lbs
9.8 ft	3861 lbs
12.5 ft	2915 lbs
14.1 ft	2442 lbs
15.4 ft	<b>2145 lbs</b>

The above load capacity chart is representative of a typical chart found in most operator manuals.

The chart is divided into two sections: One for a lift made straight over the back of the machine, and one for lifts made with the boom swung to the side. Notice how the capacity for lifts made at the same radius decreases as the backhoe is swung to the side. Maximum capacity lifts made over the rear of the machine can, if swung to the side, tip the machine over. Machines with extendable sticks have additional load charts for the stick retracted and extended.

30% reduction  
in capacity



## Attaching The Load



For buckets with lifting eyes located on the back of the bucket, use a shackle to attach the slings. Because of the sharp edges, chain slings should be used.

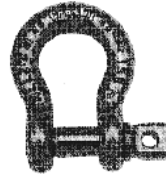

When determining where to attach the lifting sling(s) to the bucket, an operator should first refer to the operator's manual. Most manufacturers state where the load should be attached.

Some manufacturers have included a lifting eye or attachment point on the bucket. Others have designated holes on the bucket linkage as suitable lifting points.

Once a load is attached to a backhoe, the bucket should not be manipulated. Doing so could foul or damage the rigging.

## Attaching The Load To The Backhoe

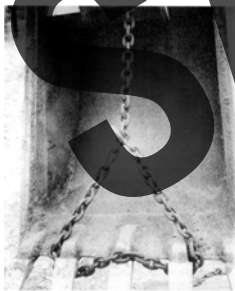

Fig. A

When attaching a chain for lifting on buckets without lifting eyes, the chain should be attached as shown in Fig. A and brought over the back of the bucket as shown in Fig. B. Never make a lift with a chain or sling attached solely to the teeth.



Fig. B

For buckets which do not have designated lifting attachment points, a chain can be attached as shown in the above figures. The backhoe bucket needs to be rotated outward so that the teeth point downward at all times during the full range of motion of the boom and the stick. The chain is attached to the bucket as shown in figure A. The chain then is placed over the back of the bucket as shown in figure B. Where the chain bends over sharp edges, blocking between the edge and the chain should be used to prevent damage to the chain. Such damage could result in chain failure.

22



## Attaching The Load To The Loader



The operator's manual for each machine includes a section on load capacity for the loader bucket. On some machines, lifting capacity is limited by the capacity of the hydraulic system. Some buckets come with lifting eyes welded to the back side. Chain slings can be attached at these points and the chain run over the front of the bucket. Blocking or some other form of protection should be used to prevent the chain from being damaged where it bends over sharp edges. Slings should not be attached to the lifting arms of the loader, or around any of the hydraulic lift cylinders.

If a load is moved by traveling the machine, it should be kept as low to the ground as possible. This will help to maintain control of the load while traveling and allow the load to be quickly lowered if it gets out of control. Always travel at the slowest speed when traveling with a suspended load.

## Lifting Objects



Various lifting hardware has been manufactured to use for different lifting applications. All hardware used for lifting must be load rated by the manufacturer and used according to their instructions. Prior to use, this hardware needs to be inspected by a competent individual. When not in use, the hardware should be stored to prevent damage and deterioration due to weather.



# Controlling Worksite Access



**Worksites need to have proper barrier/barricades to prevent unauthorized personnel and vehicles from entering the work area.**

Before excavating work begins, access to the worksite by unauthorized persons needs to be controlled. Barriers of cone, barrels or other structures can establish the work area perimeter. Caution tape, barricade safety fencing or other well-marked material should be placed between the vertical barriers to prevent people from accidentally entering the work area.



## Special Attachments



**When using special attachments, operating instructions need to be included with the operator's manual.**



Several types of backhoe attachments are currently available which extend the backhoe's versatility. Before using these devices, the operator should read and thoroughly understand how to use them.

When changing attachments, make sure all pins and pin locks are securely in place. Some attachments require additional hydraulic hoses to be strung from the tractor to the attachment. All hoses need to be securely attached to the backhoe to prevent damage during operations.



## Transporting The Machine



**Loading and unloading the machine should be by and experienced operator. Tie down chains need to be attached to the machine as to not cause damage and prevent the machine from moving in all directions.**

When preparing to transport a loader/backhoe, consult the operator's manual to identify any specific things to be done. Most backhoes have a boom swing locking pin that needs to be engaged. Also, the boom transport lock needs to be engaged.

When loading the machine onto a ramp truck or trailer, make sure wheels are blocked. Clean off any mud from the ramps to prevent the machine's slipping off them. When driving the loader/backhoe up a steep ramp, remember that the front end of the machine will be light. Therefore, accelerate slowly to keep the front wheels on the deck. Once the machine is in position for traveling, lower the loader bucket as necessary and chain the machine to the transport vehicle. Avoid running the tie-down chains over hydraulic cylinders and/or other parts that could be damaged. Tie-down chains should be installed in a cross configuration, both side to side and fore to aft.

When unloading the machine, make sure all tie-down chains are removed and the transport vehicle wheels blocked. Carefully descend the ramps, keeping the loader bucket high enough to clear the deck.